

AAVM

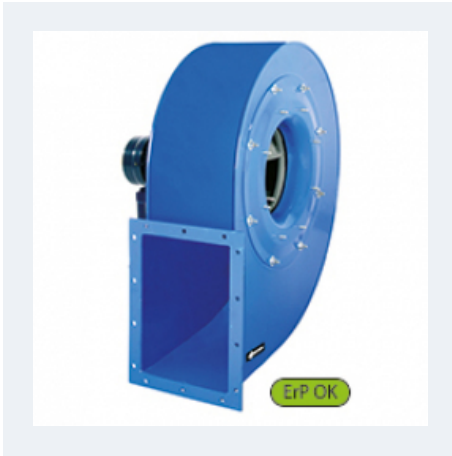

HIGH PRESSURE WITH BACKWARD IMPELLER

MANUFACTURING FEATURES:

- Fan made of Fe360 sheet. The fan paint finish is based on a Qualicoat polyester powder coating stoved at 200°C, with an average film thickness of 70 microns. Average heat resistance of coating is 180°C with peaks of 200°C.
- Fully welded housing.
- High efficiency simple inlet backward impeller with self-cleaning system made of Fe360 sheet statically and dynamically balanced. Impellers are painted with polyester primer that resists temperatures up to 300°C.
- Standard asynchronous squirrel-cage motor with IP-55 protection and class F insulation. Manufactured with standard voltages: 230/400V 50Hz in three phase motors up to 4kW and 400/690V 50Hz for higher powers.
- Standard orientation LG270.
- It allows adjusting the orientation locally from models 350 to 630. Models sizes from 710 to 1000 size the orientation is fixed.

APPLICATIONS:

Designed for inline installation, they are suitable for:

- Industrial applications, extraction or injection of air.
- Cooling of machines and parts.
- Clean and slightly dusty air transport.
- Exhaust after filters, separators and cyclones.
- Pneumatic transport.
- Maximum working temperature: carried air: 130°C, ambient: 60°C.

UNDER REQUEST

- Fans for 60Hz and special voltages.
- 2 speed motor.
- C4 or C5 coating painting
- Hot dip galvanized
- Special steel (Cor-Ten A, Hardox...)
- Inox 304 (normal or electropolished finish)
- Inox 316 (normal or electropolished finish)
- Cooling wheel
- Anticaloric paint
- Reinforced housing
- Fully welded housing (waterproof)
- Insulated housing
- Split casing (for big sizes)
- Inspection door to facilitate maintenance and cleaning
- Drain plug.
- Airtight axle
- Frontal foot
- Double suction flange
- Available in the following versions:
 - Non-sparking air passage and standard motor.
 - ATEX II2GD Ex_na
 - ATEX II2G Ex_e
 - ATEX II3GD Ex_d
- Other brands of motors.
- Orientation: RD0, RD45, RD90, RD135, RD180, RD225, RD270, RD315, LG0, LG45, LG90, LG135, LG180. LG225, LG315.

Accessories



AB



AC



AVR



AVS



BA-400



BAD



EI



FS



INT



JE 45



RA



RI



SFC

Technical data

Three-phase motor / 2 poles

Code	Model	R.P.M.	Rated I. (A) 400V	Rated power kW	Max. Airflow w m3/h	Sound db (A)**	Weight t	Connect. diagram
502803518	AAVM/N 350 T2 1,1kW	2800	2,33	1,10	1.440	66	36	1
502804027	AAVM/N 400 T2 2,2kW	2840	4,58	2,20	2.160	68	50	1
502804532	AAVM/N 450 T2 4kW	2880	7,63	4	2.880	71	80	1
502805034	AAVM/N 500 T2 5,5kW	2910	10,6	5,50	3.600	74	107	1
502805621	AAVM/N 560 T2 11kW	2940	20,8	11	5.400	77	163	1
502806326	AAVM/N 630 T2 18,5kW	2940	34,4	18,50	7.920	80	193	1
502807130	AAVM/N 711 T2 30kW	2955	56,6	30	9.000	83	390	1
502807131	AAVM/N 711 T2 37kW	2955	66,7	37	10.800	84	390	1
502808035	AAVM/N 801 T2 55kW	2960	95	55	12.600	85	664	1
502808037	AAVM/N 801 T2 75kW	2975	130	75	16.200	86	794	1
502809038	AAVM/N 901 T2 90kW	2975	156	90	18.000	88	969	1
502809022	AAVM/N 901 T2 110kW	2980	188	110	21.600	89	1.109	1
502810025	AAVM/N 1001 T2 160kW	2980	269	160	21.600	92	1.230	1
502810105	AAVM/N 1001 T2 200kW	2980	336	200	33.000	93	1.230	1
507303517	AAVM/NR 350 T2 0,75kW	2800	1,58	0,75	940	66	35	1
507304019	AAVM/NR 400 T2 1,5kW	2865	3,14	1,50	1.620	68	46	1
507304529	AAVM/NR 450 T2 3kW	2880	5,92	3	2.520	70	60	1
507305032	AAVM/NR 500 T2 4kW	2880	7,63	4	3.240	73	92	1
507305636	AAVM/NR 560 T2 7,5kW	2910	14,1	7,50	4.680	76	122	1
507306324	AAVM/NR 630 T2 15kW	2935	27,4	15	7.200	80	175	1
507307128	AAVM/NR 711 T2 22kW	2940	39,8	22	9.000	82	300	1
507308033	AAVM/NR 801 T2 45kW	2960	78	45	14.400	84	526	1
507309037	AAVM/NR 901 T2 75kW	2975	130	75	18.000	87	926	1
507310022	AAVM/NR 1001 T2 110kW	2980	188	110	18.000	91	1.220	1
507310023	AAVM/NR 1001 T2 132kW	2980	223	132	21.600	92	1.220	1

Three-phase motor / 4 poles

Code	Model	R.P.M.	Rated I. (A) 400V	Rated power kW	Max. Airflow w m3/h	Sound db (A)**	Weight t	Connect. diagram
502807161	AAVM/N 712 T4 5,5kW	1460	10,5	5,50	5.400	67	211	1
502808049	AAVM/N 802 T4 11kW	1455	21,2	11	7.920	69	286	1
502809052	AAVM/N 902 T4 15kW	1465	29,8	15	10.800	71	401	1
502810055	AAVM/N 1002 T4 22kW	1465	40,1	22	14.400	75	640	1

Code	Model	R.P.M.	Rated I. (A) 400V	Rated power kW	Max. Airflow w m3/h	Sound db (A)**	Weight	Connect. diagram
507307159	AAVM/NR 712 T4 4kW	1440	8,32	4	4.680	67	194	1
507308063	AAVM/NR 802 T4 7,5kW	1455	14,1	7,50	6.120	68	255	1
507309049	AAVM/NR 902 T4 11kW	1455	21,2	11	10.080	71	380	1
507310053	AAVM/NR 1002 T4 18,5kW	1470	35,6	18,50	12.600	74	620	1

Notes:

** Total sound pressure level at the point of maximum flow measured in dB(A) in the suction measured in free field at a distance of 6m from the source

Dimensions

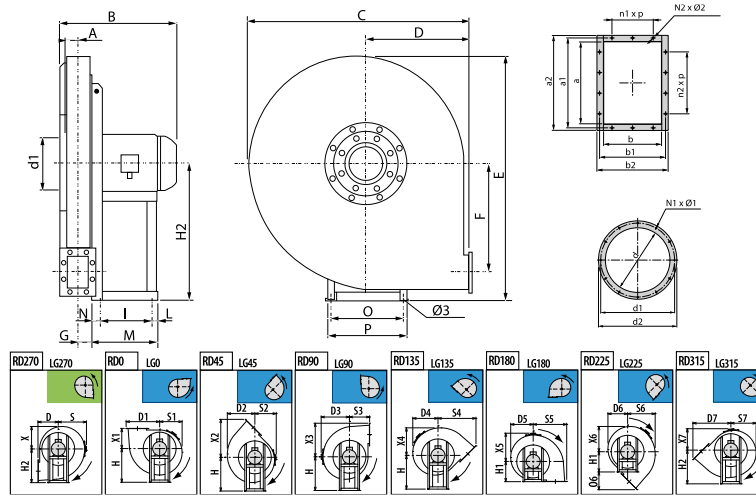

Model	A	B	C	D	D1	D2	D3	D4	D5
AAVM/N 350 T2 1,1kW	65	377	565	250	323	287	315	280	262
AAVM/N 400 T2 2,2kW	71	437	620	280	356	314	340	302	284
AAVM/N 450 T2 4kW	78	503	675	300	393	350	375	335	313
AAVM/N 500 T2 5,5kW	86	560	745	335	436	386	410	370	345
AAVM/N 560 T2 11kW	95	684	835	375	488	438	460	418	393
AAVM/N 630 T2 18,5kW	105	703	940	425	545	493	515	472	440
AAVM/N 711 T2 30kW	115	917	1045	475	610	547	570	522	493
AAVM/N 711 T2 37kW	115	917	1045	475	610	547	570	522	493
AAVM/N 712 T4 5,5kW	115	623	1045	475	610	547	570	522	493
AAVM/N 801 T2 55kW	127	1092	1170	530	682	622	640	592	555
AAVM/N 801 T2 75kW	127	1095	1170	530	682	622	640	592	555
AAVM/N 802 T4 11kW	127	753	1170	530	682	622	640	592	555
AAVM/N 901 T2 90kW	140	1122	1315	600	763	696	715	668	628
AAVM/N 901 T2 110kW	140	1334	1315	600	763	696	715	668	628
AAVM/N 902 T4 15kW	140	780	1315	600	763	696	715	668	628
AAVM/N 1001 T2 160kW	160	1366	1460	670	849	805	790	765	691
AAVM/N 1001 T2 200kW	160	1366	1460	670	849	805	790	765	691
AAVM/N 1002 T4 22kW	160	944	1460	670	849	805	790	765	691
AAVM/NR 350 T2 0,75kW	65	377	565	250	323	287	315	280	262
AAVM/NR 400 T2 1,5kW	71	437	620	280	356	314	340	302	284
AAVM/NR 450 T2 3kW	78	482	675	300	393	350	375	335	313
AAVM/NR 500 T2 4kW	86	520	745	335	436	386	410	370	345
AAVM/NR 560 T2 7,5kW	95	579	835	375	488	438	460	418	393
AAVM/NR 630 T2 15kW	105	703	940	425	545	493	515	472	440
AAVM/NR 711 T2 22kW	115	809	1045	475	610	547	570	522	493

Model	A	B	C	D	D1	D2	D3	D4	D5
AAVM/NR 712 T4 4kW	115	583	1045	475	610	547	570	522	493
AAVM/NR 801 T2 45kW	127	984	1170	530	682	622	640	592	555
AAVM/NR 802 T4 7,5kW	127	648	1170	530	682	622	640	592	555
AAVM/NR 901 T2 75kW	140	1122	1315	600	763	696	715	668	628
AAVM/NR 902 T4 11kW	140	780	1315	600	763	696	715	668	628
AAVM/NR 1001 T2 110kW	160	1366	1460	670	849	805	790	765	691
AAVM/NR 1001 T2 132kW	160	1366	1460	670	849	805	790	765	691
AAVM/NR 1002 T4 18,5kW	160	893	1460	670	849	805	790	765	691

Model	D6	D7	E	F	G	H	H1	H2	I
AAVM/N 350 T2 1,1kW	272	405	617	215	56	355	250	355	121
AAVM/N 400 T2 2,2kW	293	450	659	238	63	375	280	375	133
AAVM/N 450 T2 4kW	319	490	713	265	70	400	300	400	197
AAVM/N 500 T2 5,5kW	350	546	795	297	78	450	335	450	237
AAVM/N 560 T2 11kW	392	613	893	337	88	500	375	500	337
AAVM/N 630 T2 18,5kW	438	688	1000	381	98	560	425	560	337
AAVM/N 711 T2 30kW	489	767	1123	426	108	630	475	630	381
AAVM/N 711 T2 37kW	489	767	1123	426	108	630	475	630	381
AAVM/N 712 T4 5,5kW	489	767	1123	426	108	630	475	630	237
AAVM/N 801 T2 55kW	545	854	1265	481	121	710	530	710	501
AAVM/N 801 T2 75kW	545	854	1265	481	121	710	530	710	591
AAVM/N 802 T4 11kW	545	854	1265	481	121	710	530	710	337
AAVM/N 901 T2 90kW	617	963	1428	542	134	800	600	800	591
AAVM/N 901 T2 110kW	617	963	1428	542	134	800	600	800	675
AAVM/N 902 T4 15kW	617	963	1428	542	134	800	600	800	337
AAVM/N 1001 T2 160kW	640	1074	1591	607	150	900	670	900	675
AAVM/N 1001 T2 200kW	640	1074	1591	607	150	900	670	900	675
AAVM/N 1002 T4 22kW	640	1074	1591	607	150	900	670	900	357
AAVM/NR 350 T2 0,75kW	272	405	617	215	56	355	250	355	121
AAVM/NR 400 T2 1,5kW	293	450	659	238	63	375	280	375	133
AAVM/NR 450 T2 3kW	319	490	713	265	70	400	300	400	197
AAVM/NR 500 T2 4kW	350	546	795	297	78	450	335	450	197
AAVM/NR 560 T2 7,5kW	392	613	893	337	88	500	375	500	237
AAVM/NR 630 T2 15kW	438	688	1000	381	98	560	425	560	337
AAVM/NR 711 T2 22kW	489	767	1123	426	108	630	475	630	357
AAVM/NR 712 T4 4kW	489	767	1123	426	108	630	475	630	197
AAVM/NR 801 T2 45kW	545	854	1265	481	121	710	530	710	421
AAVM/NR 802 T4 7,5kW	545	854	1265	481	121	710	530	710	237
AAVM/NR 901 T2 75kW	617	963	1428	542	134	800	600	800	591
AAVM/NR 902 T4 11kW	617	963	1428	542	134	800	600	800	337

Model	D6	D7	E	F	G	H	H1	H2	I
AAVM/NR 1001 T2 110kW	640	1074	1591	607	150	900	670	900	675
AAVM/NR 1001 T2 132kW	640	1074	1591	607	150	900	670	900	675
AAVM/NR 1002 T4 18,5kW	640	1074	1591	607	150	900	670	900	357

Model	L	M	N	N1xØ1	N2xØ2	O	O6	P	S
AAVM/N 350 T2 1,1kW	45	211	45	8x8	6x12	203	155	225	315
AAVM/N 400 T2 2,2kW	58	246	55	8x8	6x12	234	170	260	340
AAVM/N 450 T2 4kW	49	276	30	8x8	6x12	289	190	324	375
AAVM/N 500 T2 5,5kW	59	336	40	8x10	8x12	337	211	372	410
AAVM/N 560 T2 11kW	49	436	50	8x12	8x12	395	238	440	460
AAVM/N 630 T2 18,5kW	49	436	50	8x12	10x12	395	263	440	515
AAVM/N 711 T2 30kW	39	500	80	8x12	10x12	506	292	568	570
AAVM/N 711 T2 37kW	39	500	80	8x12	10x12	506	292	568	570
AAVM/N 712 T4 5,5kW	59	336	40	8x12	10x12	337	292	372	570
AAVM/N 801 T2 55kW	39	600	60	12x12	10x12	604	324	690	640
AAVM/N 801 T2 75kW	46	697	60	12x12	10x12	690	324	750	640
AAVM/N 802 T4 11kW	49	436	50	12x12	10x12	395	324	440	640
AAVM/N 901 T2 90kW	46	697	60	12x12	10x12	690	363	750	715
AAVM/N 901 T2 110kW	45	800	80	12x12	10x12	760	363	865	715
AAVM/N 902 T4 15kW	49	436	50	12x12	10x12	395	363	440	715
AAVM/N 1001 T2 160kW	45	800	80	12x14	14x12	760	404	865	790
AAVM/N 1001 T2 200kW	45	800	80	12x14	14x12	760	404	865	790
AAVM/N 1002 T4 22kW	33	460	70	12x14	14x12	434	404	488	790
AAVM/NR 350 T2 0,75kW	45	211	45	8x8	6x12	203	155	225	315
AAVM/NR 400 T2 1,5kW	58	246	55	8x8	6x12	234	170	260	340
AAVM/NR 450 T2 3kW	49	276	30	8x8	6x12	289	190	324	375
AAVM/NR 500 T2 4kW	49	276	30	8x10	8x12	289	211	324	410
AAVM/NR 560 T2 7,5kW	59	336	40	8x12	8x12	337	238	372	460
AAVM/NR 630 T2 15kW	49	436	50	8x12	10x12	395	263	440	515
AAVM/NR 711 T2 22kW	33	460	70	8x12	10x12	434	292	488	570
AAVM/NR 712 T4 4kW	49	276	30	8x12	10x12	289	292	324	570
AAVM/NR 801 T2 45kW	39	540	80	12x12	10x12	556	324	616	640
AAVM/NR 802 T4 7,5kW	59	336	40	12x12	10x12	337	324	372	640
AAVM/NR 901 T2 75kW	46	697	60	12x12	10x12	690	363	750	715
AAVM/NR 902 T4 11kW	49	436	50	12x12	10x12	395	363	440	715
AAVM/NR 1001 T2 110kW	45	800	80	12x14	14x12	760	404	865	790
AAVM/NR 1001 T2 132kW	45	800	80	12x14	14x12	760	404	865	790
AAVM/NR 1002 T4 18,5kW	33	460	70	12x14	14x12	434	404	488	790

Model	S1	S2	S3	S4	S5	S6	S7	X	X1
AAVM/N 350 T2 1,1kW	262	272	250	405	323	287	280	262	250
AAVM/N 400 T2 2,2kW	284	293	280	450	356	314	302	284	280
AAVM/N 450 T2 4kW	313	319	300	490	393	350	335	313	300
AAVM/N 500 T2 5,5kW	345	350	335	546	436	386	370	345	335
AAVM/N 560 T2 11kW	393	392	375	613	488	438	418	393	375
AAVM/N 630 T2 18,5kW	440	438	425	688	545	493	472	440	425
AAVM/N 711 T2 30kW	493	489	475	767	610	547	522	493	475
AAVM/N 711 T2 37kW	493	489	475	767	610	547	522	493	475
AAVM/N 712 T4 5,5kW	493	489	475	767	610	547	522	493	475
AAVM/N 801 T2 55kW	555	545	530	854	682	622	592	555	530
AAVM/N 801 T2 75kW	555	545	530	854	682	622	592	555	530
AAVM/N 802 T4 11kW	555	545	530	854	682	622	592	555	530
AAVM/N 901 T2 90kW	628	617	600	963	763	696	668	628	600
AAVM/N 901 T2 110kW	628	617	600	963	763	696	668	628	600
AAVM/N 902 T4 15kW	628	617	600	963	763	696	668	628	600
AAVM/N 1001 T2 160kW	691	640	670	1074	849	805	765	691	670
AAVM/N 1001 T2 200kW	691	640	670	1074	849	805	765	691	670
AAVM/N 1002 T4 22kW	691	640	670	1074	849	805	765	691	670
AAVM/NR 350 T2 0,75kW	262	272	250	405	323	287	280	262	250
AAVM/NR 400 T2 1,5kW	284	293	280	450	356	314	302	284	280
AAVM/NR 450 T2 3kW	313	319	300	490	393	350	335	313	300
AAVM/NR 500 T2 4kW	345	350	335	546	436	386	370	345	335
AAVM/NR 560 T2 7,5kW	393	392	375	613	488	438	418	393	375
AAVM/NR 630 T2 15kW	440	438	425	688	545	493	472	440	425
AAVM/NR 711 T2 22kW	493	489	475	767	610	547	522	493	475
AAVM/NR 712 T4 4kW	493	489	475	767	610	547	522	493	475
AAVM/NR 801 T2 45kW	555	545	530	854	682	622	592	555	530
AAVM/NR 802 T4 7,5kW	555	545	530	854	682	622	592	555	530
AAVM/NR 901 T2 75kW	628	617	600	963	763	696	668	628	600
AAVM/NR 902 T4 11kW	628	617	600	963	763	696	668	628	600
AAVM/NR 1001 T2 110kW	691	640	670	1074	849	805	765	691	670
AAVM/NR 1001 T2 132kW	691	640	670	1074	849	805	765	691	670
AAVM/NR 1002 T4 18,5kW	691	640	670	1074	849	805	765	691	670

Model	X2	X3	X4	X5	X6	X7	a	a1	a2
AAVM/N 350 T2 1,1kW	405	323	287	315	280	272	146	182	216
AAVM/N 400 T2 2,2kW	450	356	314	340	302	293	166	200	236
AAVM/N 450 T2 4kW	490	393	350	375	335	319	185	219	255
AAVM/N 500 T2 5,5kW	546	436	386	410	370	350	207	241	277
AAVM/N 560 T2 11kW	613	488	438	460	418	392	231	265	301

Model	X2	X3	X4	X5	X6	X7	a	a1	a2
AAVM/N 630 T2 18,5kW	688	545	493	515	472	438	258	292	328
AAVM/N 711 T2 30kW	767	610	547	570	522	489	288	332	368
AAVM/N 711 T2 37kW	767	610	547	570	522	489	288	332	368
AAVM/N 712 T4 5,5kW	767	610	547	570	522	489	288	332	368
AAVM/N 801 T2 55kW	854	682	622	640	592	545	322	366	402
AAVM/N 801 T2 75kW	854	682	622	640	592	545	322	366	402
AAVM/N 802 T4 11kW	854	682	622	640	592	545	322	366	402
AAVM/N 901 T2 90kW	963	763	696	715	668	617	361	405	441
AAVM/N 901 T2 110kW	963	763	696	715	668	617	361	405	441
AAVM/N 902 T4 15kW	963	763	696	715	668	617	361	405	441
AAVM/N 1001 T2 160kW	1074	849	805	790	765	640	404	448	484
AAVM/N 1001 T2 200kW	1074	849	805	790	765	640	404	448	484
AAVM/N 1002 T4 22kW	1074	849	805	790	765	640	404	448	484
AAVM/NR 350 T2 0,75kW	405	323	287	315	280	272	146	182	216
AAVM/NR 400 T2 1,5kW	450	356	314	340	302	293	166	200	236
AAVM/NR 450 T2 3kW	490	393	350	375	335	319	185	219	255
AAVM/NR 500 T2 4kW	546	436	386	410	370	350	207	241	277
AAVM/NR 560 T2 7,5kW	613	488	438	460	418	392	231	265	301
AAVM/NR 630 T2 15kW	688	545	493	515	472	438	258	292	328
AAVM/NR 711 T2 22kW	767	610	547	570	522	489	288	332	368
AAVM/NR 712 T4 4kW	767	610	547	570	522	489	288	332	368
AAVM/NR 801 T2 45kW	854	682	622	640	592	545	322	366	402
AAVM/NR 802 T4 7,5kW	854	682	622	640	592	545	322	366	402
AAVM/NR 901 T2 75kW	963	763	696	715	668	617	361	405	441
AAVM/NR 902 T4 11kW	963	763	696	715	668	617	361	405	441
AAVM/NR 1001 T2 110kW	1074	849	805	790	765	640	404	448	484
AAVM/NR 1001 T2 132kW	1074	849	805	790	765	640	404	448	484
AAVM/NR 1002 T4 18,5kW	1074	849	805	790	765	640	404	448	484

Model	b	b1	b2	d	d1	d2	n1xp	n2xp	Ø3
AAVM/N 350 T2 1,1kW	105	139	175	185	219	250	-	1x112	10
AAVM/N 400 T2 2,2kW	117	151	187	205	241	275	-	1x112	10
AAVM/N 450 T2 4kW	131	165	201	228	265	298	-	1x112	12
AAVM/N 500 T2 5,5kW	148	182	218	255	292	325	1x112	1x112	12
AAVM/N 560 T2 11kW	166	200	236	285	332	365	1x112	1x112	14
AAVM/N 630 T2 18,5kW	185	219	255	320	366	400	1x112	2x112	14
AAVM/N 711 T2 30kW	205	249	285	360	405	440	1x125	2x125	19
AAVM/N 711 T2 37kW	205	249	285	360	405	440	1x125	2x125	19
AAVM/N 712 T4 5,5kW	205	249	285	360	405	440	1x125	2x125	12
AAVM/N 801 T2 55kW	229	273	309	405	448	485	1x125	2x125	19

Model	b	b1	b2	d	d1	d2	n1xp	n2xp	Ø3
AAVM/N 801 T2 75kW	229	273	309	405	448	485	1x125	2x125	21
AAVM/N 802 T4 11kW	229	273	309	405	448	485	1x125	2x125	14
AAVM/N 901 T2 90kW	256	300	336	455	497	535	1x125	2x125	21
AAVM/N 901 T2 110kW	256	300	336	455	497	535	1x125	2x125	24
AAVM/N 902 T4 15kW	256	300	336	455	497	535	1x125	2x125	14
AAVM/N 1001 T2 160kW	288	332	368	505	551	585	2x125	3x125	24
AAVM/N 1001 T2 200kW	288	332	368	505	551	585	2x125	3x125	24
AAVM/N 1002 T4 22kW	288	332	368	505	551	585	2x125	3x125	17
AAVM/NR 350 T2 0,75kW	105	139	175	185	219	250	-	1x112	10
AAVM/NR 400 T2 1,5kW	117	151	187	205	241	275	-	1x112	10
AAVM/NR 450 T2 3kW	131	165	201	228	265	298	-	1x112	12
AAVM/NR 500 T2 4kW	148	182	218	255	292	325	1x112	1x112	12
AAVM/NR 560 T2 7,5kW	166	200	236	285	332	365	1x112	1x112	12
AAVM/NR 630 T2 15kW	185	219	255	320	366	400	1x112	2x112	14
AAVM/NR 711 T2 22kW	205	249	285	360	405	440	1x125	2x125	17
AAVM/NR 712 T4 4kW	205	249	285	360	405	440	1x125	2x125	12
AAVM/NR 801 T2 45kW	229	273	309	405	448	485	1x125	2x125	19
AAVM/NR 802 T4 7,5kW	229	273	309	405	448	485	1x125	2x125	12
AAVM/NR 901 T2 75kW	256	300	336	455	497	535	1x125	2x125	21
AAVM/NR 902 T4 11kW	256	300	336	455	497	535	1x125	2x125	14
AAVM/NR 1001 T2 110kW	288	332	368	505	551	585	2x125	3x125	24
AAVM/NR 1001 T2 132kW	288	332	368	505	551	585	2x125	3x125	24
AAVM/NR 1002 T4 18,5kW	288	332	368	505	551	585	2x125	3x125	17

Wiring diagram

DIAGRAM N° 1

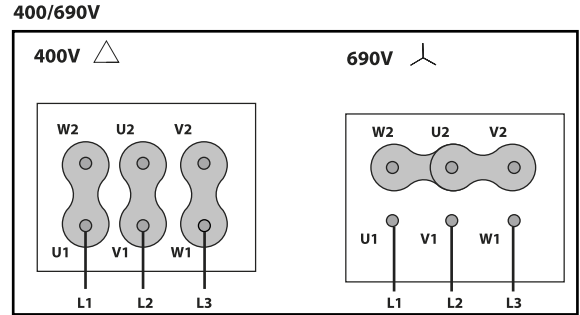
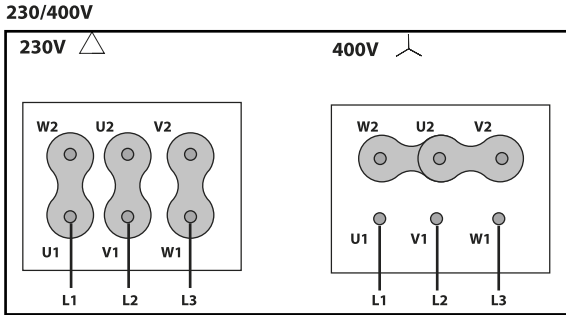

CHARACTERISTIC CURVE

1	AAVM/N 350 T2 1,1kW	2	AAVM/N 400 T2 2,2kW	3	AAVM/N 450 T2 4kW	4	AAVM/N 500 T2 5,5kW
5	AAVM/N 560 T2 11kW	6	AAVM/N 630 T2 18,5kW	7	AAVM/N 711 T2 30kW	8	AAVM/N 711 T2 37kW
9	AAVM/N 801 T2 55kW						

AIR FLOW - PRESSURE



1	AAVM/N 801 T2 75kW	2	AAVM/N 901 T2 90kW	3	AAVM/N 901 T2 110kW	4	AAVM/N 1001 T2 160kW
5	AAVM/N 1001 T2 200kW	6	AAVM/NR 350 T2 0,75kW	7	AAVM/NR 400 T2 1,5kW	8	AAVM/NR 450 T2 3kW

AIR FLOW - PRESSURE

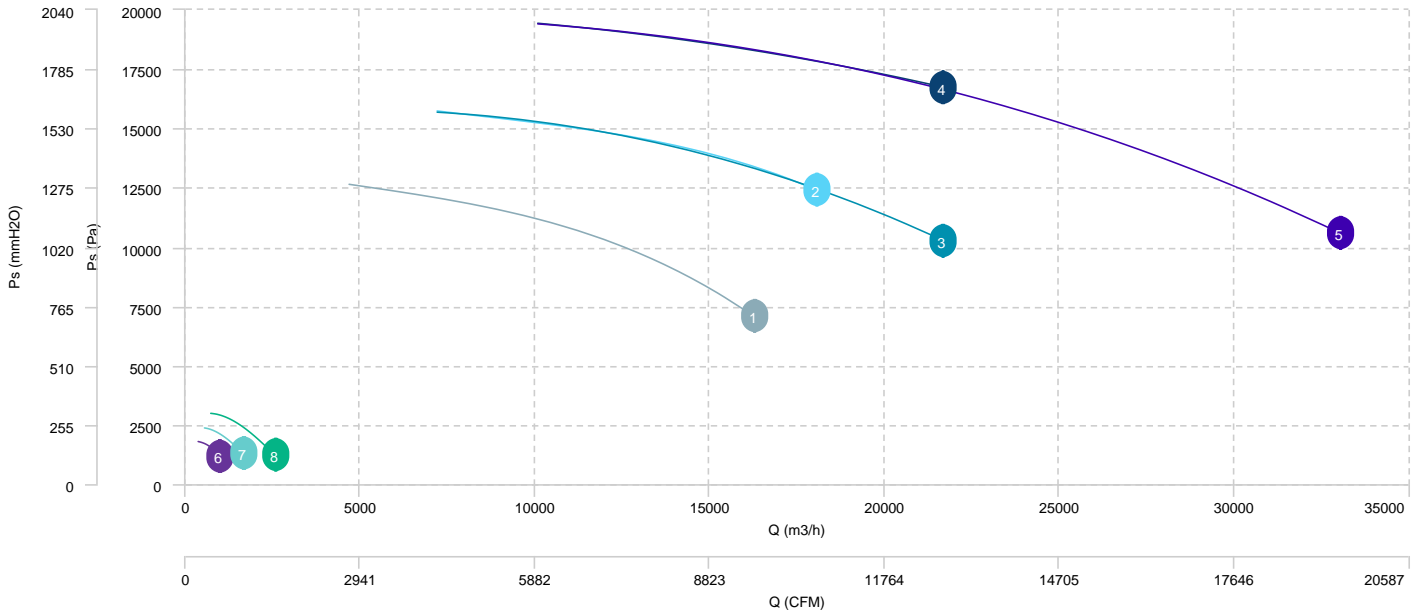

1	AAVM/NR 500 T2 4kW	2	AAVM/NR 560 T2 7,5kW	3	AAVM/NR 630 T2 15kW	4	AAVM/NR 711 T2 22kW
5	AAVM/NR 801 T2 45kW	6	AAVM/NR 901 T2 75kW	7	AAVM/NR 1001 T2 110kW	8	AAVM/NR 1001 T2 132kW

AIR FLOW - PRESSURE

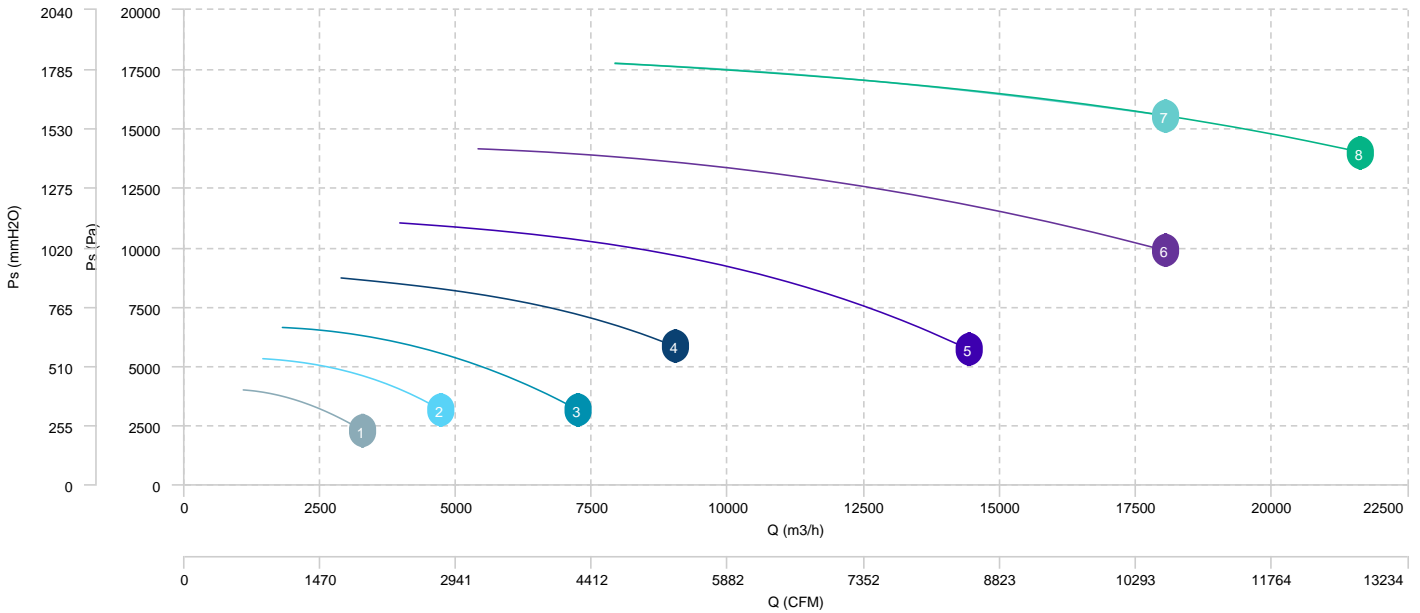

1	AAVM/N 712 T4 5,5kW	2	AAVM/N 802 T4 11kW	3	AAVM/N 902 T4 15kW	4	AAVM/N 1002 T4 22kW
5	AAVM/NR 712 T4 4kW	6	AAVM/NR 802 T4 7,5kW	7	AAVM/NR 902 T4 11kW	8	AAVM/NR 1002 T4 18,5kW

AIR FLOW - PRESSURE

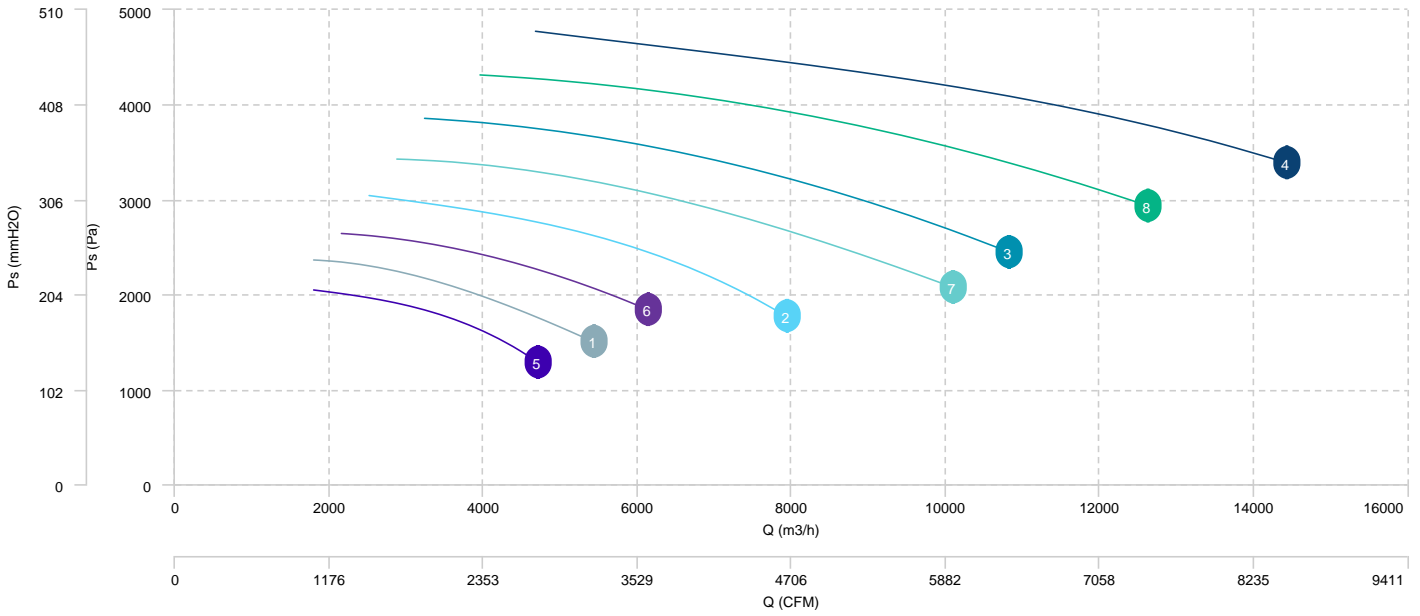

Sound data

Sound / 2 poles

Sound power Lw dB (A)										
Model		63 Hz	125 Hz	250 Hz	500 Hz	1000 Hz	2000 Hz	4000 Hz	8000 Hz	Total
AAVM/N 350 T2 1,1kW	Inlet	60	72	76	85	88	87	80	73	92
AAVM/N 400 T2 2,2kW	Inlet	62	73	77	87	90	89	82	74	94
AAVM/N 450 T2 4kW	Inlet	64	76	80	89	93	91	84	77	97
AAVM/N 500 T2 5,5kW	Inlet	68	80	84	93	96	95	88	81	100
AAVM/N 560 T2 11kW	Inlet	71	83	87	96	99	98	91	84	103
AAVM/N 630 T2 18,5kW	Inlet	74	86	90	99	102	101	94	87	106
AAVM/N 711 T2 30kW	Inlet	77	89	93	102	105	104	97	90	109
AAVM/N 711 T2 37kW	Inlet	77	89	93	102	106	104	97	90	110
AAVM/N 801 T2 55kW	Inlet	78	90	94	103	107	105	98	91	111
AAVM/N 801 T2 75kW	Inlet	79	91	95	104	108	106	99	92	112
AAVM/N 901 T2 90kW	Inlet	82	94	98	107	110	109	102	95	114
AAVM/N 901 T2 110kW	Inlet	83	95	99	108	111	110	103	96	115
AAVM/N 1001 T2 160kW	Inlet	86	98	102	111	114	113	106	99	118
AAVM/N 1001 T2 200kW	Inlet	87	99	103	112	115	114	107	100	119
AAVM/NR 350 T2 0,75kW	Inlet	60	72	76	85	88	87	80	73	92
AAVM/NR 400 T2 1,5kW	Inlet	61	73	77	86	90	88	81	74	94
AAVM/NR 450 T2 3kW	Inlet	64	76	80	89	92	91	84	77	96
AAVM/NR 500 T2 4kW	Inlet	67	79	83	92	95	94	87	80	99
AAVM/NR 560 T2 7,5kW	Inlet	70	82	86	95	98	97	90	83	102
AAVM/NR 630 T2 15kW	Inlet	74	86	90	99	102	101	94	87	106
AAVM/NR 711 T2 22kW	Inlet	76	88	92	101	104	103	96	89	108
AAVM/NR 801 T2 45kW	Inlet	78	90	94	103	106	105	98	91	110
AAVM/NR 901 T2 75kW	Inlet	81	93	97	106	109	108	101	94	113
AAVM/NR 1001 T2 110kW	Inlet	85	97	101	110	113	112	105	97	117
AAVM/NR 1001 T2 132kW	Inlet	85	97	101	110	114	112	105	98	118

Sound / 4 poles

Sound power Lw dB (A)										
Model		63 Hz	125 Hz	250 Hz	500 Hz	1000 Hz	2000 Hz	4000 Hz	8000 Hz	Total
AAVM/N 712 T4 5,5kW	Inlet	61	73	77	86	89	88	81	74	93
AAVM/N 802 T4 11kW	Inlet	63	75	79	88	91	90	83	76	95
AAVM/N 902 T4 15kW	Inlet	66	77	81	90	93	92	85	78	97
AAVM/N 1002 T4 22kW	Inlet	69	81	85	94	97	95	89	81	101

Sound power Lw dB (A)										
Model		63 Hz	125 Hz	250 Hz	500 Hz	1000 Hz	2000 Hz	4000 Hz	8000 Hz	Total
AAVM/NR 712 T4 4kW	Inlet	61	73	77	86	89	88	81	74	93
AAVM/NR 802 T4 7,5kW	Inlet	62	74	78	87	90	89	82	75	94
AAVM/NR 902 T4 11kW	Inlet	65	77	81	90	93	92	85	78	97
AAVM/NR 1002 T4 18,5kW	Inlet	68	80	84	93	96	95	88	81	100